

SPECIFICATION OF DIAPHRAGM
 TEMPERATURE 0~140°C
 PRESSURE 0.490~0.264MPa

SPECIFICATION OF BODY POLISHING
 INTERNAL:#400 BUFF+ E.P.
 EXTERNAL: E.P. (SURFACE REMAIN FORGED)

VALVE TO BE MOUNTED ON PIPE LIKE
 THE MARK CAN BE FACED UPWARD.

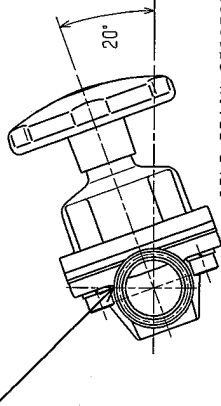

SELF-DRAIN POSITION

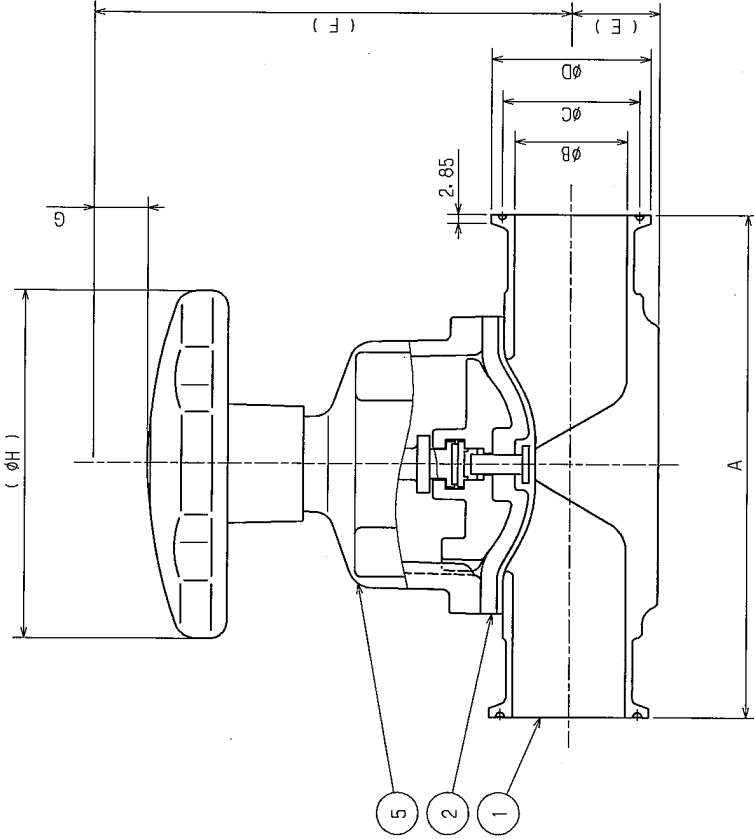

SIZE	A	B	C	D	E	F	G	H	I	ITEM NO.
10 A	108	14	27.5	34	16	90	7	65	52	BW2-A1-7C-F
15 A	108	17.5	27.5	34	16	90	7	65	52	BW2-A1-7D-F
1 S	127	23	43.5	50.5	19	114	10	80	75	BW2-A1-7F-F
1 1/2 S	159	35.7	43.5	50.5	28	151	17	110	100	BW2-A1-7H-F
2 S	190	47.8	56.5	64	36	185	26	110	120	BW2-A1-7I-F

CAREER	CONTRAST TABLE		UNIT (mm)	THE THIRD ANGLE	DRAWING SYMBOL												
	NOMINAL SIZE (A)	NOMINAL SIZE (B)															
	6	8	10	15	20	25	32	40	50	65	80	100	125	150	200	250	
	1/8	1/4	3/8	1/2	3/4	1	1 1/4	1 1/2	2	2 1/2	3	3 1/2	4	5	6	8	10
	OUTSIDE DIAMETER	10.5	13.8	17.3	21.7	27.2	34.0	42.7	53.6	66.5	76.3	89.1	107.4	133.8	165.2	216.3	287.4

REVISION		
REV. NO.	DATE	REVISED DESCRIPTION

REMARK DIMENSIONS IN PARENTHESES IS FOR REFERENCE.
 DIMENSIONS OF FERULE CONFORMS TO ISO.
 THIS DRAWING SHOWS ONLY OUTSIDE DIMENSIONS.
 AS TO INSIDE STRUCTURE AND PARTS LIST.
 PLEASE REFER TO ATTACHED DRAWING.
 DRG. NO. UI92830E

PART. NO.	NAME OF PARTS	MATERIAL	QTY	REMARK
5	ACTUATOR	ADC12	1	PTFE COATED
4	WASHER	SUS304	4	
3	CAP BOLT	SUS304	4	
2	DIAPHRAGM	PTFE/BUTYL	1	
1	BODY	SUSF316L	1	

MATERIAL LIST			
DATE	'00.1.29	TEST PRESS.	MPa
SCALE	FREE	FLUID HYDRO	GN2
APPD.	T. Sato	SHELL	0.736
CHKD.	T. Okamoto	SEAT	0.540
DESIGN	T. Hamana	BACKSEAT	
RECIPIENT		SEAL	0.540

MODEL NO.	TRACE MARK OR MODEL NAME	NAME	DRG. NO.	REV. MARK
		STAINLESS STEEL CLAMP TYPE DIAPHRAGM VALVE	UI93619E	0

Fujikin Incorporated
 株式会社フジキン

170	BWM	CAB. NO.
ASBW04	19	