

RECIPIENT \_\_\_\_\_

UNIT (mm) THE THIRD ANGLE 

REMARK

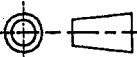
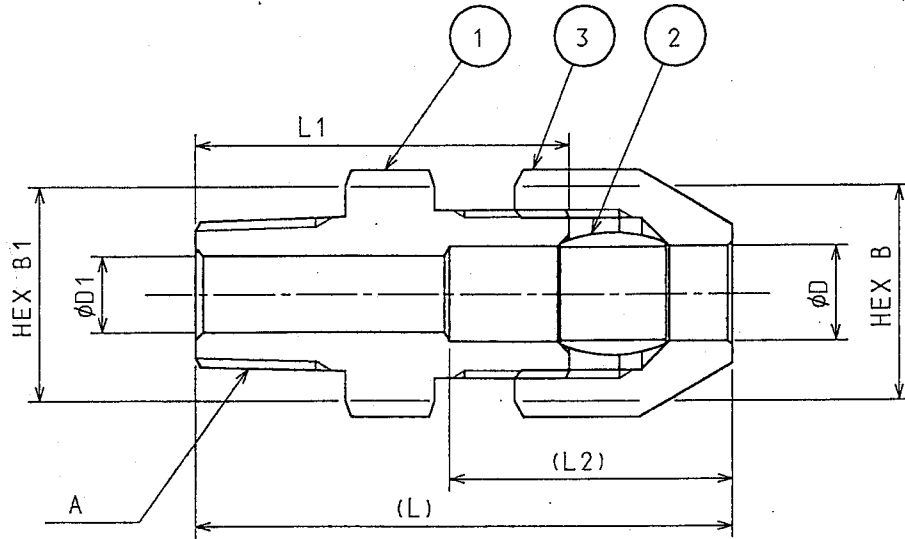

| NOMINAL DIA D | A    | D1 | B  | B1 | L    | L1   | L2 | ITEM No. |
|---------------|------|----|----|----|------|------|----|----------|
| 6             | R1/8 | 5  | 14 | 14 | 35   | 25   | 19 | RH-6A    |
| 6             | R1/4 | 5  | 14 | 14 | 39   | 29   | 19 | RH-6B    |
| 6             | R3/8 | 5  | 14 | 17 | 41   | 31   | 19 | RH-6C    |
| 6             | R1/2 | 5  | 14 | 23 | 46   | 36   | 19 | RH-6D    |
| 8             | R1/8 | 6  | 14 | 14 | 35   | 25   | 19 | RH-8A    |
| 8             | R1/4 | 6  | 14 | 14 | 39   | 29   | 19 | RH-8B    |
| 8             | R3/8 | 6  | 14 | 17 | 41   | 31   | 19 | RH-8C    |
| 8             | R1/2 | 6  | 14 | 23 | 46   | 36   | 19 | RH-8D    |
| 10            | R1/8 | 6  | 17 | 14 | 40   | 29   | 23 | RH-10A   |
| 10            | R1/4 | 8  | 17 | 14 | 43   | 32   | 23 | RH-10B   |
| 10            | R3/8 | 8  | 17 | 17 | 45   | 34   | 23 | RH-10C   |
| 10            | R1/2 | 8  | 17 | 23 | 50   | 39   | 23 | RH-10D   |
| 10            | R3/4 | 8  | 17 | 29 | 54   | 43   | 23 | RH-10E   |
| 12            | R1/8 | 6  | 19 | 17 | 45.5 | 32   | 27 | RH-12A   |
| 12            | R1/4 | 8  | 19 | 17 | 48.5 | 35   | 27 | RH-12B   |
| 12            | R3/8 | 10 | 19 | 19 | 50   | 36.5 | 27 | RH-12C   |
| 12            | R1/2 | 10 | 19 | 23 | 54.5 | 41   | 27 | RH-12D   |
| 12            | R3/4 | 10 | 19 | 29 | 58.5 | 45   | 27 | RH-12E   |

|               |                                    |  |                            |               |     |           |               |          |              |        |           |
|---------------|------------------------------------|--|----------------------------|---------------|-----|-----------|---------------|----------|--------------|--------|-----------|
| NO.           | DATE                               | CONTENTS   | REVISED                    | APPD.         | 14  |           |               |          |              |        |           |
|               |                                    |  |                            |               | 13  |           |               |          |              |        |           |
|               |                                    |  |                            |               | 12  |           |               |          |              |        |           |
| REVISION      |                                    |  |                            |               | 11  |           |               |          |              |        |           |
| DATE          | '81-02-04                          | T<br>E<br>S<br>T<br>I<br>N<br>G<br>P<br>A<br>R<br>T<br>S<br>D<br>I<br>A<br>G<br>R<br>A<br>M<br>S<br>C<br>H<br>E<br>M<br>E<br>S<br>I<br>C<br>H<br>E<br>M<br>I<br>C<br>A<br>L<br>P<br>R<br>O<br>P<br>E<br>R<br>T<br>I<br>E<br>S<br>T<br>I<br>N<br>G<br>M<br>E<br>T<br>H<br>O<br>D<br>S<br>I<br>N<br>S<br>P<br>E<br>C<br>T<br>I<br>O<br>N<br>S<br>C<br>H<br>E<br>M<br>E<br>S<br>I<br>C<br>H<br>E<br>M<br>I<br>C<br>A<br>L<br>P<br>R<br>O<br>P<br>E<br>R<br>T<br>I<br>E<br>S<br>T<br>I<br>N<br>G<br>M<br>E<br>T<br>H<br>O<br>D<br>S<br>I<br>N<br>S<br>P<br>E<br>C<br>T<br>I<br>O<br>N<br>S | Kgf/cm <sup>2</sup><br>MPa | HYDRO         | AIR | 10        |               |          |              |        |           |
| SCALE         | FREE                               |  | SHELL                      | /             | /   |           | 9             |          |              |        |           |
| APPD.         | A. Maeda                           |  | SEAT                       | /             | /   |           | 8             |          |              |        |           |
| CHKD.         | J. Shikata                         |  | BACK SEAT                  | /             | /   |           | 7             |          |              |        |           |
| DESIGN        | S. Nagusa                          |  | SEAL                       | /             | /   |           | 6             |          |              |        |           |
| ITEM NO.      |                                    |  |                            |               |     | 5         |               |          |              |        |           |
| TRADEMARK     |                                    |  |                            |               |     | 4         |               |          |              |        |           |
| NAME          | BRASS RING JOINT<br>MALE CONNECTOR |  |                            |               |     | 3         | UNION NUT     | C3604B   | 1 Ni PLATING |        |           |
|               |                                    |  |                            |               |     | 2         | RING          | C3602B   | 1            |        |           |
|               |                                    |  |                            |               |     | 1         | BODY          | C3604B   | 1 Ni PLATING |        |           |
|               |                                    |  |                            |               |     | PART. NO. | NAME OF PARTS | MATERIAL | Q. TY        | REMARK | G. T. NO. |
| MATERIAL LIST |                                    |  |                            |               |     |           |               |          |              |        |           |
|               |                                    |  |                            |               |     | DRG. NO.  | D33955E       |          | REV. MARK    | 3      |           |
| CAREER        | '95-02-24                          | REWRITE  | S. NAGUSA                  | 070           | RJ  |           |               |          |              |        |           |
|               |                                    |  |                            | RJ-KUMIZU (E) | 1   | CAB. NO.  |               |          |              | 1-9    |           |